



1615 Tech Drive, Bay City, MI 48706  
Ph 989-686-8920 Fx 989-686-6520

## INSTRUCTIONS

1. Adjust the shift rod on transmission to the position as seen in figure 1.1 below. The transmission should come from the factory pre-set in first gear.

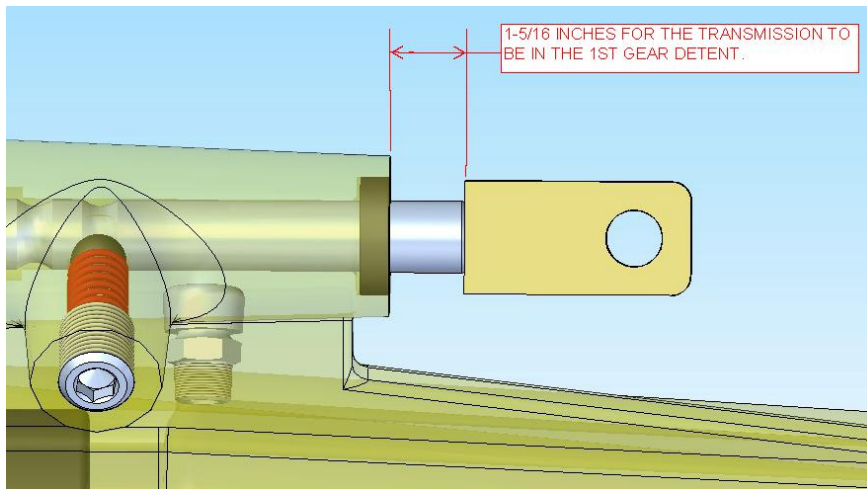

Figure 1.1

2. The shifting mechanism must be set and adjusted to the 1<sup>st</sup> gear "F" setting. Mount the shifter in the car and hold the shift lever to the first gear position. Connect the adjustable shift linkage to the transmission and adjust the turnbuckle style linkage so the lever is against the "F" setting. Lock down the rod ends with the supplied jam nuts. Minor adjustments may need to be made during track testing. Shifter must be mounted rigid in the car. Flexing in the sheet metal can cause the shifter to go out of adjustment.
3. **Use only Brinn RT1 Transmission fluid with the Predator transmission.** No other fluid is approved for this unit. The transmission is filled through the blue fill plug on the right side of the case.
4. A starter bottle of RT1 oil is supplied with your new transmission. This is the exact amount of fluid needed to properly fill the transmission.
5. Recommended fluid changes are as follows:
  - a. First 3 race nights - change the fluid after every night.
  - b. After the 3<sup>rd</sup> night - change every other race night.
6. **DO NOT REMOVE the steel plug on the lower driver side of the transmission case.** This is the clutch anchor. Removal of this plug is only done during rebuilding and disassembly.
7. **DO NOT USE WITH ¾" MASTER CYLINDER.** This clutch is designed to be used with 7/8" or 1" master cylinders.